

Power Relay G6RN

Heavy-duty Miniature Relay

- Incorporates environmentally-friendly, cadmium-free contacts.
- Variety of contact forms: SPDT or SPST-NO (continuous current rating: 8 A).
- Low profile (0.39 W x 1.12 L x 0.59 H inches)
- High dielectric strength of 4 kV with 8 mm creepage/clearance.
- Sealed plastic construction.
- Ideal for switching contactors, solenoids and motors.

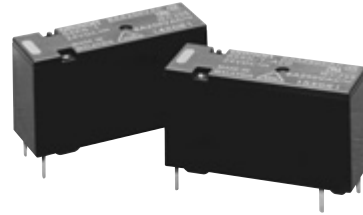

Ordering Information

Classification	Structure	Contact material	Contact form	
			SPST-NO	SPDT
Standard	Plastic-sealed	AgNi + gold plating	G6RN-1A	G6RN-1

Note: When ordering, add the rated coil voltage to the model number.

Example: G6RN-1A 24 VDC
 └───┬───┘ Rated coil voltage

Model Number Legend

G6RN-□□□□□ - □
 1 2 3 4 5 6

1. Number of poles

1: 1 pole

2. Contact form

None: SPDT
 A: SPST-NO

3. Contact type

None: Single contact

4. Enclosure ratings

None: Plastic-sealed

5. Terminals

None: Standard PCB

6. Contact material

None: AgNi + gold plating
 ACD: AgCdO + gold plating

Specifications

■ Coil Ratings

Rated voltage	5 VDC	6 VDC	12 VDC	24 VDC	48 VDC
Rated current	44 mA	36.7 mA	18.3 mA	9.2 mA	5.2 mA
Coil resistance	114 Ω	164 Ω	655 Ω	2,620 Ω	9,210 Ω
Must operate voltage	70% max. of rated voltage				
Must release voltage	10% min. of rated voltage				
Max. voltage	110% of rated voltage				
Power consumption	Approx. 220 mW				Approx. 250 mW

Note: 1. The rated current and coil resistance are measured at a coil temperature of 23°C with a tolerance of ±10%.
2. Operating characteristics are measured at a coil temperature of 23°C.

■ Contact Ratings

Contact type	Single contact
Configuration	SPDT, SPST-NO
Contact material	AgNi + gold plating (standard)
Max. switching voltage	250 VAC, 125 VDC
Rated switching current	8 A at 250 VAC 5 A at 30 VDC
Max. switching capacity	2,000 VA, 150 W
Min. permissible load	10 mA, 5 VDC

Note: Current value for switching 125 VDC is 0.15 A resistive and 0.1 A inductive (L/R = 7 ms).

■ Characteristics

Contact resistance	100 mΩ max.	
Operate time	Approx. 6 ms	
Release time	Approx. 3 ms	
Max. operating frequency	Mechanical	36,000 operations/hr
	Electrical	360 operations/hr (under rated load)
Insulation resistance	1,000 MΩ min.	
Dielectric strength	4,000 VAC: between coil and contacts	
	1,000 VAC: between contacts	
Creepage/clearance	8 mm min. between coil and contacts	
Vibration resistance	Malfunction	NO: 10 to 55 Hz, 1.5 mm double amplitude
		NC: 10 to 55 Hz, 0.8 mm double amplitude
Shock resistance	Destruction	1,000 m/s ² (approx. 100 G)
	Malfunction	100 m/s ² (approx. 10 G)
Life expectancy	Mechanical	10,000,000 operations min.
	Electrical	Approx. 100,000 operations (see note)
Ambient temperature	Operating	-40°C to 85°C
	Storage	-40°C to 85°C
Ambient humidity	Operating	35% to 85%
Weight	Approx. 9 g	
Protection class	II according to VDE0106 Part 1	
Insulation class	C/250 according to VDE0110	

Note: Resistive load test at 250 VAC, 8 A, room temperature with diode.
Continuous monitoring must be performed to detect contact sticking and short circuit.
Dielectric strength measured at 500 V for 1 minute with the same polarity.

■ Approved Standards

IEC255 (Includes Reinforced Insulation and Spacing Requirements According to IEC65, 335-1, 940, EN60335-1, 60950)

Standard	Contact form	Coil ratings	Contact ratings	Conditions
IEC255-1-00 IEC255-0-20	SPDT SPST-NO	5, 6, 12, 24, 48 VDC	8 A at 250 VAC (cosφ =1) (see note)	Pollution degree: 3 Overvoltage category: II Operating range: class 1 Pick-up class: class C Ambient temperature: -40°C to 85°C

Note: VAC according to IEC417.

VDE

Standard	Contact form	Coil ratings	Contact ratings	Conditions
VDE0435 Part201 VDE0435 Part120	SPDT SPST-NO	5, 6, 12, 24, 48 VDC	8 A at 250 VAC (cosφ =1)	Insulation group according to VDE0110 C/250 Operating range: class 1 Pick-up class: class C Ambient temperature: -40°C to 85°C

UL File No. E41515

CSA (File No. LR31928)

Standard	Contact form	Coil ratings	Contact ratings
UL508	SPDT SPST-NO	5, 6, 12, 24, 48 VDC	250 VAC, 10 A resistive 250 VAC, 8 A resistive, 85°C 30 VDC, 5 A

Engineering Data

Maximum Switching Power

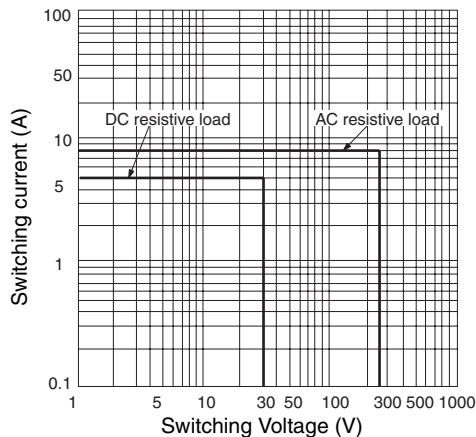

Endurance

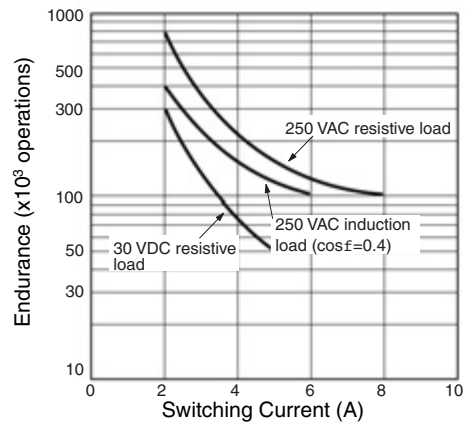

Ambient Temperature vs Maximum Coil Voltage

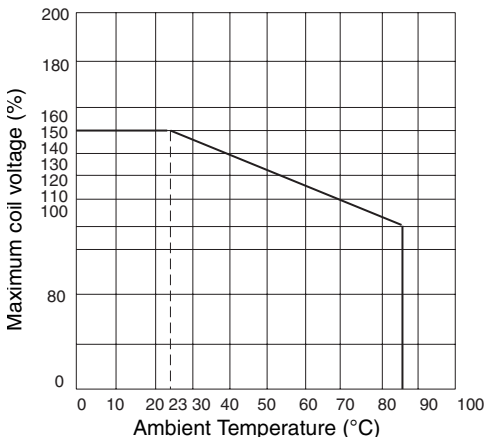

Note: The maximum coil voltage refers to the maximum value in a varying range of operating power voltage, not a continuous voltage.

Dimensions

Unit: mm (inch)

■ SPDT Type

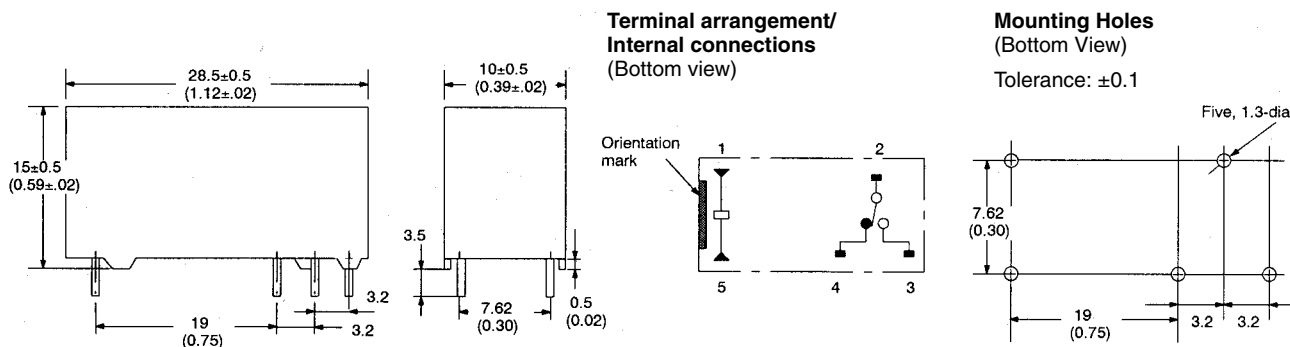

■ SPST-NO Type

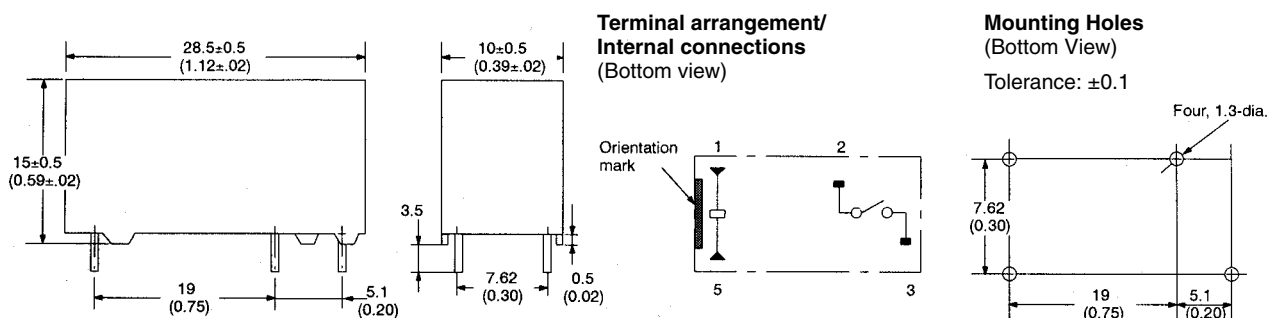

ALL DIMENSIONS SHOWN ARE IN MILLIMETERS. To convert millimeters into inches, divide by 25.4



OMRON ELECTRONICS LLC
One Commerce Drive
Schaumburg, IL 60173
847-882-2288

OMRON CANADA, INC.
885 Milner Avenue
Toronto, Ontario M1B 5V8
416-286-6465

OMRON ON-LINE
Global - <http://www.omron.com>
USA - <http://www.omron.com/oei>
Canada - <http://www.omron.ca>